

A Novel Dual Power Flow Interface For EV, Hev, And Phev Applications With Converter

P.V.S.Aditya¹, K.Sujesh², CH.Nagalaxmi³,⁴ S.Kiran Kumar^{1,2,&3} Assistant Professor

Dept. Of Eee, Holy Mary Institute Of Technology And Science
 Bogaram(V), Keesara(M), R.Rdist, Hyderabad.

⁴assistant Professor Dept. Of Eee, Nagole Institute Of Technology And Science
 Bogaram(V), Keesara(M), R.Rdist, Hyderabad.

Abstrac: This paper on a universal power electronic interface that can be utilized in electric vehicles, hybrid electric vehicles, and plug-in hybrid electric vehicles (PHEVs). Basically, this converter interfaces the energy storage de-vice of the vehicle with the motor drive and the external charger, in case of PHEVs. The proposed converter is operates in buck or boost modes with non-converted voltage and bidirectional power flow.

I. INTRODUCTION

Electrification of the transportation industry is essential due to the improvements in higher fuel economy, better performance, and lower emissions. In vehicular applications, power electronic dc/dc converters require high power bidirectional flow capability with wide input range since the terminal voltage of energy storage devices varies with the state of charge (SoC) and load variations. In the case of a hybrid electric vehicle (HEV), a bidirectional dc/dc converter interfaces the energy storage device with the motor drive inverter of the traction machine; i.e., the converter is placed between the battery and the high-voltage dc bus. In acceleration or cruising mode, it should deliver power from the battery to the dc link, whereas in regenerative mode, it should deliver power from the dc link to the battery. In the case of an EV or plug-in hybrid electric vehicle (PHEV), while accomplishing the afore-mentioned task, the bidirectional dc/dc converter also interfaces the battery with the ac/dc converter during charging/discharging from/to grid. Therefore, the bidirectional dc/dc converter

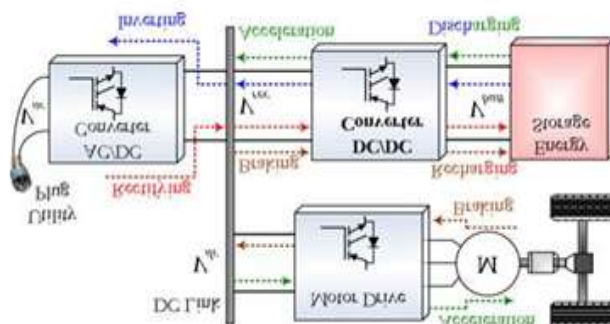

Fig. 1. Power electronic interfaces in an electric vehicle..

Fig. 1 illustrates the role of the bidirectional dc/dc converter in the electrical power system of a plug-in electric vehicle. In grid-connected mode, the bidirectional dc/dc converter must have the capability to convert the output voltage of the ac/dc converter into a suitable voltage to recharge the batteries and vice versa when injecting power to the grid. In driving mode, dc/dc converter should be able to regulate the dc link voltage for wide range of input voltages. In driving mode, usually the battery voltage is stepped-up during acceleration. DC link voltage is stepped-down during braking, where $V_{dc} > V_{batt}$.

However, if motor drive's nominal voltage is less than battery's nominal voltage, $V_{dc} < V_{batt}$, the battery voltage should be stepped-down during acceleration and the dc link voltage should be stepped-up during regenerative braking. In addition to these cases, in an HEV to PHEV conversion, the grid interface converter's output voltage might be less or more than the battery's nominal voltage, depending on the grid's V_{ac} voltage and the grid interface converter's topology. The rectified grid voltage should be stepped-up if $V_{rec} < V_{batt}$ in V2G charging mode or the battery voltage should be stepped-up for V2G discharging mode. If the rectified grid voltage is more than the battery's nominal voltage, i.e., $V_{rec} > V_{batt}$, the rectified voltage should be stepped-down in V2G charging mode and the battery voltage should be stepped-up in V2G discharging mode.

When all these possibilities are considered, the need for a universal bidirectional dc/dc converter is obvious which should be capable of operating in all-directions with stepping-up and stepping-down functionalities. Such a universal converter would meet all the needs of the auto industry.

The proposed converter in this manuscript not only fulfills these conditions, but also can be utilized for retrofit conversion of conventional cars to HEVs as well as the HEV to PHEV conversions. It can be placed between the energy storage device and the high-voltage bus of the vehicle regardless of the nominal voltage ratings of the battery, motor drive, and the grid interface converter inputs and outputs. Therefore, the proposed converter is called a fully directional converter.

This paper is organized as follows. In Section II, the topological overview and the operation modes are presented. The analytical model of the converter and the control system development is given in Section III. Section IV focuses on the simulation and experimental results to evaluate and validate the capabilities of the proposed converter. Finally, the conclusion remarks and future work are provided in Section V.

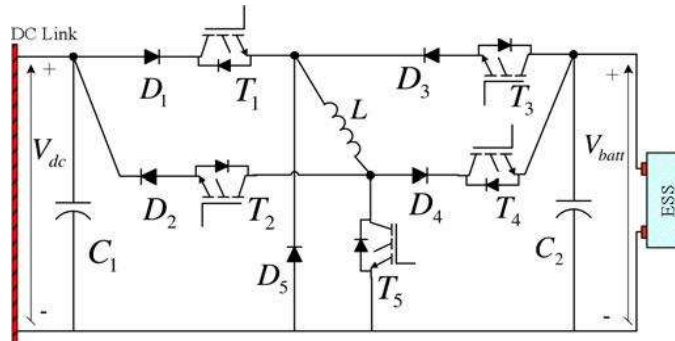

Fig. 2. Proposed fully directional universal dc/dc converter.

II. SYSTEM DESCRIPTION AND OPERATING MODES

The circuit schematic of the proposed converter is depicted in Fig. 2. The converter has five power switches (T_{1-5}) with internal diodes and five power diodes ($D_1 - D_5$), which are going to be properly combined to select buck and boost modes of operation. Here, V_{dc} represents the motor drive nominal input voltage during driving mode or the rectified ac voltage at the output of the grid interface converter during plug-in mode (also the input voltage of the grid interface converter to be inverted to ac). The nominal voltage of the vehicle's ESS is represented by V_{batt} .

The proposed converter is capable of operating from V_{dc} to boosting, V_{dc} to V_{batt} bucking, V_{batt} to V_{dc} boosting, or to V_{dc} bucking, all with positive output voltage. In any of the four modes, only one of the power switches is operated in pulse width modulation (PWM) mode, while all the other switches are completely ON or OFF.

Therefore, the switching losses are not more than that of any conventional buck or boost converter. In addition, the proposed converter requires only one high-current inductor unlike some of the existing buck and boost converter combinations or the cascaded configurations. Conventional buck–boost converters can step-up or step-down the input voltage. However, they are not capable of providing bidirectional power flow. Moreover, their output voltage is negative with respect to the input voltage, which needs an inverting transformer to make the output voltage positive. The non inverted operation capability of the proposed converter totally eliminates the need for an inverting transformer, which reduces the overall size and cost. Although there are some non-inverted topologies, some of them require two or more switches being operated in PWM mode that causes higher total Switching losses

Table Ioperation Modes Of The Proposed Converter

Direction	Mode	T_1	T_2	T_3	T_4	T_5
$V_{dc} \rightarrow V_{batt}$	BOOST	ON	OFF	OFF	ON	PWM
$V_{dc} \rightarrow V_{batt}$	BUCK	PWM	OFF	OFF	ON	OFF
$V_{batt} \rightarrow V_{dc}$	BOOST	OFF	ON	ON	OFF	PWM
$V_{batt} \rightarrow V_{dc}$	BUCK	OFF	ON	PWM	OFF	OFF

Among these topologies, although they provide buck or boost operations, bidirectional power flow cannot be achieved in the topologies of and the conventional two-quadrant bidirectional converters would operate buck mode in one direction and boost mode in the other direction; however, they cannot operate vice versa. They would not step-up the voltage in the direction that they can step-down. Two cascaded two-quadrant bidirectional converters may achieve bidirectional power flow with bucking or boosting capabilities; however, they require more than one high-current inductor, although two switches and two inductors are used, only unidirectional bucking or boosting can be achieved. In the case of a dual-active bridge dc/dc converter, all switches are operated in PWM mode; therefore, switching losses are four times higher in the half-bridge case or eight times higher in full-bridge case than that of the proposed converter.

Dual-active bridge dc/dc converters also require a transformer at the middle stage which would increase the overall losses, size, and cost. In , two inductors are required in addition to the transformer, and in the number of inductors is three. In , bidirectional power flow is possible with ten switches and two inductors. Although soft switching strategies can be considered for dual-active bridge dc/dc converters in order to reduce the switching losses such as in [23], there should be eight power switches and eight power diodes with three inductors; therefore, a high number of components would not be economical. Moreover, having more than one switch operating in PWM mode would make the control system more complicated. However, in the proposed converter, the controls are as simple as the conventional buck or boost dc/dc converters in spite of all the competences. Finally, in, the proposed dc/dc converter requires two transformers with one being multisided which complicates the structure, adds up to cost, and it does not have the bidirectional operating capability The operation capabilities of the proposed converter significantly increases the flexibility of the converter while offering a broad range of application areas in all HEV and PHEV applications as well as their conventional to HEV or HEV to PHEV conversions with add-on batteries regardless of the voltage ratings of the motor drive, battery, and the grid interface converter

The different operation modes of the converter, including the status of the corresponding switches in each mode and the direction of power flow, are mapped in Table I. T_2 and T_4 serve as simple ON/OFF switches to connect or disconnect the corresponding current flow paths, whereas T_1 , T_3 , and T_5 are either ON/OFF or PWM switches with respect to . V_{dc} -to- V_{batt} boost mode of operation. Fig. 5. V_{dc} -to- V_{batt} buck mode of operation

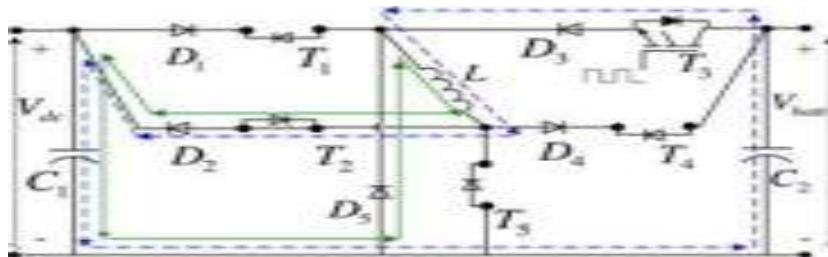

Fig.4

Fig. 4. V_{batt} -to- V_{dc} buck mode of operation corresponding operating mode. Different cases and operating modes of the converter are detailed in following sections.

A. Case 1: $V_{dc} < V_{batt}$

If the rated dc link voltage is less than battery’s rated voltage, the dc link voltage should be stepped-up during charging in grid-connected mode and in regenerative braking during driving. Under the same voltage condition, the battery voltage should be stepped-down during plug-in discharging in grid-connected mode, and in acceleration or cruising during driving.

Mode 1) $V_{dc} \rightarrow V_{batt}$ *Boost Mode for Plug-in Charging and Regenerative Braking:* In this mode, T_1 and T_4 are kept ON, while T_2 and T_3 remain in the OFF state, as shown in Fig. 3. The PWM switching signals are applied to switch T_5 . Therefore, from V_{dc} to V_{batt} , a boost converter is formed by D_1 , T_1 , L , T_5 , D_4 , and T_4 . Since D_1 and D_4 are forward-biased, they conduct; whereas D_3 and D_2 do not conduct. Since T_5 is in PWM switching mode, when it is turned ON, the current from V_{dc} flows through D_1 , T_1 , L , and T_5 while energizing the inductor. When T_5 is OFF, both the source and the inductor currents flow to the battery side through D_4 and T_4 .

During this mode, V_{dc} and V_{batt} sequentially become the in-put and output voltages. Since the inductor current is a state vari-able of this converter, it is controllable. Therefore, the charging power delivered to the battery in plug-in mode or high-voltage bus current in regenerative braking can be controlled.

Mode 2) $V_{batt} \rightarrow V_{dc}$ Buck Mode for Plug-in Discharging and Acceleration: The circuit schematic of this operation mode is provided in Fig. 4. In this mode, T_1 , T_4 , and T_5 remain OFF, while T_2 is kept in ON state all the time. The PWM switching signals are applied to switch T_3 . Therefore, from V_{batt} to V_{dc} , a buck converter is formed by T_3 , D_3 , D_5 , L , T_2 , and D_2 . When T_3 is turned ON, the current from the battery passes through T_3 , D_3 , L , T_2 , and D_2 , while energizing the inductor. When T_3 is OFF, the output current is freewheeled through the D_5 , T_2 , and D_2 , decreasing the average current transferred to the load side. D_3 and D_2 are forward-biased, whereas D_1 and D_4 do not conduct. D_5 only conducts when T_3 is OFF.

In this mode, V_{batt} and V_{dc} are the input and output voltages, respectively. During stepping-down the battery voltage while delivering power from battery to the dc link, the inductor is at the output and its current is a state variable. Therefore, the dc link voltage and the current delivered to the dc link can be controlled in driving mode.

B. Case 2: $V_{dc} > V_{batt}$

If the rated dc link voltage is more than the battery’s rated voltage, dc link voltage should be stepped-down during charging in grid-connected mode and in regenerative braking while the vehicle is being driven. Under the same voltage condition, the battery voltage should be stepped-up during plug-in discharging in grid-connected mode and in acceleration or cruising while driving.

Mode 3) $V_{dc} \rightarrow V_{batt}$ Buck Mode for Plug-in Charging and Regenerative Braking: In this mode, T_1 is in the PWM switching mode. Switches T_2 , T_3 , and T_5 remain in OFF state while T_4 is kept ON all the time. Therefore, from V_{dc} to V_{batt} , a buck converter is made up by D_1 , T_1 , D_5 , L , D_4 and T_4 as shown in Fig. 5. When T_1 is turned ON, the current from V_{dc} passes through D_1 , T_1 , L , D_4 , and T_4 while energizing the inductor. When T_1 is OFF, the output current is recovered by freewheeling diode D_5 decreasing the average current transferred from dc link to the battery. Since diodes D_1 and D_4 are forward-biased, they conduct whereas D_2 and D_3 do not conduct. D_5 only conducts when T_1 is OFF. In this mode, V_{dc} and V_{batt} are the input and output voltages, respectively. The dc link voltage can be regulated in driving mode (regenerative braking) by controlling the current transferred to the battery. In plug-in charging mode, the current or power delivered to the battery is also controllable.

Mode 4) $V_{batt} \rightarrow V_{dc}$ Boost Mode for Plug-in Discharging and Acceleration: During this mode, T_1 and T_4 remain OFF, whereas T_2 and T_3 remain ON all the time. Switch T_5 is operated in PWM switching mode. Therefore, from V_{batt} to V_{dc} , a boost converter is formed by T_3 , D_3 , L , T_5 , T_2 , and D_2 , as illustrated in Fig. 6. When T_5 is turned ON, the current from V_{batt} passes through T_3 , D_3 , L , and T_5 while energizing the inductor. When T_5 is OFF, both inductor and the source currents pass through T_2 and D_2 to the dc link. In this mode, D_3 and D_2 are forward-biased and they cond.9. DC/DC converter charge/discharge power

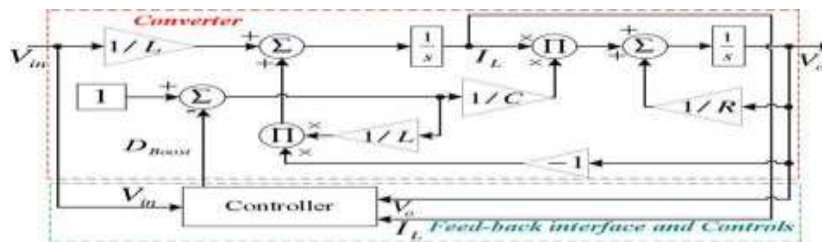

Fig.7. State-space model of the simplified converter in boost mode

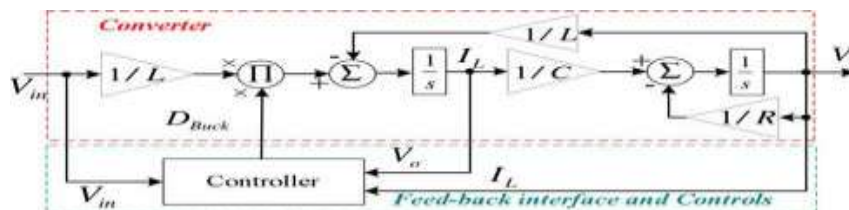

Fig. 8. State-space model of the simplified converter in buck mode Whereas D_1 , D_4 , and D_5 are reverse-biased and do not conduct. In this mode, V_{batt} and V_{dc} are sequentially the input and output voltages. The dc link voltage can be regulated in driving mode (regenerative braking) by controlling the current drawn from the battery. In plug-in charging mode, the current or power drawn from battery is also controllable.

III. CONTROL SYSTEMS

For the control system of the proposed topology, an all-electric range focused operating strategy has been considered. As described in Section II and shown in Figs. 3–6, all operation modes of the proposed converter are combinations of buck and boost operations with different configurations and input/output voltages, as expressed in Table I. Therefore, simplified state-space averaged large-signal transfer functions of the buck or boost modes of operations can be derived. The state-space block diagrams for the boost and buck modes of operations of the proposed converter are shown in Figs. 7 and Two different controllers are incorporated for the proposed system: one employed in plug-in charging/discharging and the other is for acceleration/deceleration during driving.

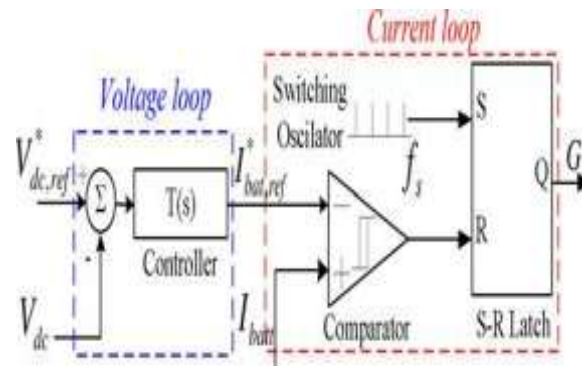

Fig.10. DC/DC converter's cascaded controller for driving mode

VI. CONCLUSION

The functionalities of the proposed converter provide a broad range of application areas. Due to the operational capabilities, the proposed converter is one of a kind plug-and-play universal dc/dc converter that is suitable for all electric vehicle applications. The proposed topology is suitable not only for conversion approaches but also is a good candidate to reduce the number of dc/dc converters from two to one in commercially available vehicles such as Toyota Prius. Through the simulation results and experimental prototype, the functionalities for two different cases with four different modes have been verified. In each case, bidirectional power flow is provided with fully directional bucking and boosting capabilities

REFERENCES

- [1]. A. Emadi, Y. L. Lee, and R. Rajashekar, "Power electronics and motor drives in electric, hybrid electric, and plug-in hybrid electric vehicles," *IEEE Trans. Ind. Electron.*, vol. 55, no. 6, pp. 2237–2245, Jun. 2008.
- [2]. R. Ghorbani, E. Bibeau, and S. Filizadeh, "On conversion of electric vehicles to plug-in," *IEEE Trans. Veh. Technol.*, vol. 59, no. 4, pp. 2016–2020, May 2010.
- [3]. F. H. Khan, L. M. Tolbert, and W. E. Webb, "Bi-directional power management and fault tolerant feature in a 5-kW multilevel dc-dc converter with modular architecture," *IET Power Electron.*, vol. 2, no. 5, pp. 595–604, 2009.
- [4]. G. Zorpette, "The smart hybrid," *IEEE Spectrum*, vol. 41, no. 1, pp. 44–47, Jan. 2004.
- [5]. Energy Independence and Security Act of 2007 (CLEAN Energy Act of 2007), *One Hundred Tenth Congress of the United States of America*, At the First Session, Washington DC Jan. 2007.